

TWIN AIR FILTER



Twin air Filter details :

FEATURE :-

- Borosilicate filtering element.
- 99.99% compressed filtered air upto 1 micron.
- Suitable for modular mounting.
- Press type manual drain for easy operation.
- Separator for efficient moisture separation.
- Steel bowl guard.

FUNCTION :-

- Removes submicronic oil, Water droplets and solid contaminants from compressed air.
- Used for high efficient filtration of compressed air, removing fine oil particles and droplets of size upto 0.1 micron

PRECAUTIONS:-

- Note the direction of flow before installation and connect pipe accordingly.
- Flush piping for dust, dirt, rust and other foreign particles.
- Install in clean atmosphere.
- Polycarbonate bowls may get damaged and possibly fail if exposed to synthetic oils, thinner, solvents, Kerosene or other aromatic hydrocarbons.

Technical Specifications:

Model	2016-Twin AIR FILTER
Medium	Compressed air
Port Size	G1/2 BSP (F) / G1/4 BSP (F)
Bowl capacity (ml)	44
Flow rate (Ltr / Min)	1500
Maximum supply pressure (bar)	10
Bowl material	Polycarbonate
Ambient / Medium temperature	-10° to +50° C
Installation	Vertical (As in the picture)
Materials of construction	Polycarbonite, Borosilicate , MS, Nitrile, AL
Optional accessories	Clamp, Modular mounting kit
Weight (Kg)	1.200

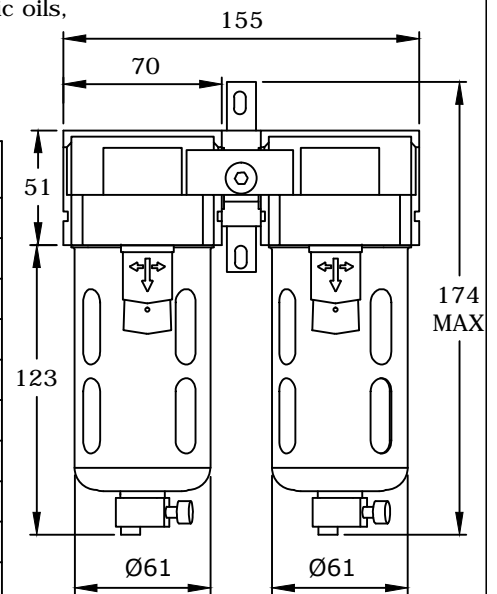

APPLICATIONS :

These type of moisture separators are used in chemical, Pharmaceuticals, Food industry, Paint shops, Powder coating machines.



Manufactured by :

Kushako India

Office : 490, Narayan Peth, Opp. Pune Marathi Granthalaya, Pune - 411030. (Maharashtra), Website : www.kushakoindia.com

Works : Sr.No. 25/1A, Village Nanded, Sinhgad Road, Tal - Haveli, Dist. Pune -411041

Tel. No : 901169077 / 7620674777

E-mail : kushako.india@gmail.com / kushakoindia1992@gmail.com